

(replaces datasheets 1010/23)

General description

An accurate proportioner for foam concentrate, irrespective of flow and pressure variations is vital for the correct performance of a foam system.

The new Skum PPW proportioners provide more accurate proportioning, a wider flow range with a lower line pressure drop than the original units.

Application description

This type of proportioner is used in foam pump and closed head sprinkler systems. The PPW series is designed for monitor and deluge systems or where large flow variations occur.

Product features

- Designed for foam mixing up to 3%
- Corrosion resistant design
- Maximum flow rate ratio of 120:1
- Accurate proportioning over the range
- Maintenance free construction
- Compact design
- Foam proportioning as low as 100 l/min

Installation

- Water: wafer mounted between flanges, see table
- Foam: flanged to fit DIN or ANSI, see table



PPW-200

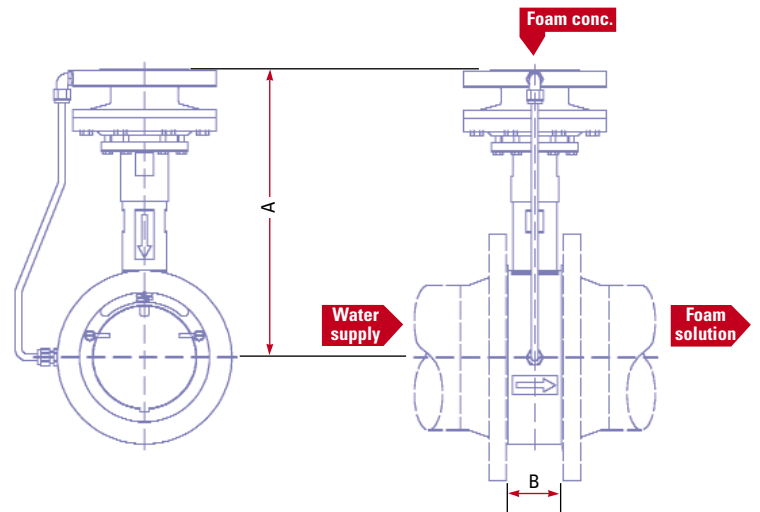

PP-200

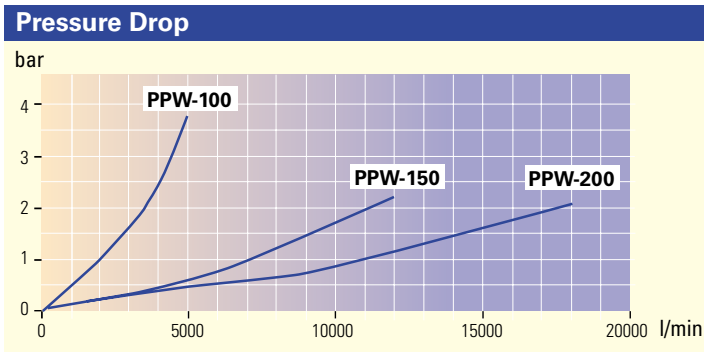
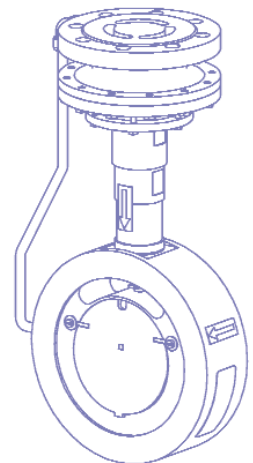

www.skum.com

DELTA FIRE AUSTRALASIA Pty Ltd

PO Box 2149, Mansfield 4122 Australia
 Unit 4, 44 Devlan Street, Mansfield, Qld 4122
 Ph: +61 7 3349 7817
 Fax: +61 7 3219 4182
 Email: sales@deltafire.com.au
 Web: www.deltafire.com.au

tyco Fire Suppression & Building Products

Technical changes reserved without notice Copyright © 2007 Tyco Safety Products

Balanced Pressure Proportioner - Mk2

PPW

Datasheet 1010/44

Page 2 of 2

(replaces datasheets 1010/23)

Operation

Fully automatic foam proportioning within the flow and pressure range. The foam inlet pressure must be at least 1 bar higher than the water pressure.

Fitting

A minimum of five diameters (D) of straight pipe is required in the water line before entering the proportioner and three diameters (D) after the proportioner. Minimum distance for water pressure into tank upstream of the PPW is four diameters (D) and maximum distance is 10 metres.

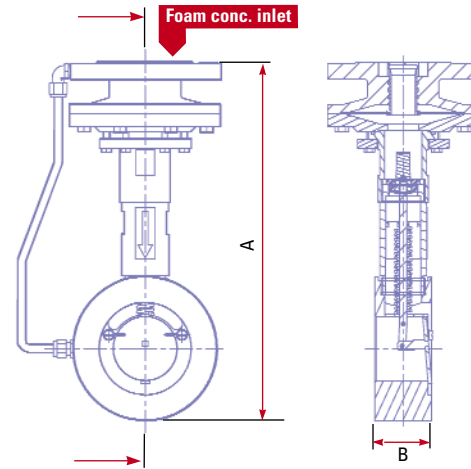

Listings and approvals

- Det Norske Veritas (DNV)
- Tested according to and complying with EN 13565-1 NFPA 16 and 30

Order information - please specify:

1. PPW size (e.g. PPW-200)
2. Foam connection (ANSI or DIN)
3. Type of foam concentrate (see matrix below) and mixing rate (%)

Matrix for Foam Concentrate Figuration

AFFF 3%	AFFF 1%	AR AFFF 3%	AR AFFF 1%	HotFoam 2%	FP 3%	P 3%	FFFP 3%
A	B	C	D	E	F	G	H

Dimensions PPW

Type	A mm	B mm
PPW-100	312	62
PPW-150	333	62
PPW-200	411	82

Performance Data

Type	Connection		Capacity				Weight		Material
			Min.		Max.*		kg	lbs	
	Foam	Water	l/min	USGPM	l/min	USGPM			
PPW-100	50 / 2"	100 / 4"	100	26	5,000	1,321	19	42	Bronze (Cu88Sn12)
PPW-150	50 / 2"	150 / 6"	100	26	12,000	3,170	22	48	Bronze (Cu88Sn12)
PPW-200	80 / 3"	200 / 8"	175	46	18,000	4,756	44	97	Bronze (Cu88Sn12)

*At proportioner system pressure drop 1.5 bar, Min. 0.3 bar $Q \text{ l/min.} \div \sqrt{P \text{ bar}} = k\text{-factor}$
 1 bar = 0,1 MPa = 14,5 psi Max. working pressure: 16 bar/235 psi



www.skum.com

DELTA FIRE AUSTRALASIA Pty Ltd

PO Box 2149, Mansfield 4122 Australia
 Unit 4, 44 Devlan Street, Mansfield, Qld 4122
 Ph: +61 7 3349 7817
 Fax: +61 7 3219 4182
 Email: sales@deltafire.com.au
 Web: www.deltafire.com.au

tyco / Fire Suppression & Building Products

Technical changes reserved without notice Copyright © 2007 Tyco Safety Products